



CAPACITY

3,000 lbs. @ 24" Load Center

INTEGRAL BATTERY / CHARGER

24-volt maintenance free batteries with direct connect 110VAC plug-in automatic charger.

S22-128 (2)12V 100AH

SPEED

TRAVEL

Variable from 0 mph to 3.2 mph empty
Variable from 0 mph to 3.0 mph loaded

LIFT

Up to 39.0 fpm empty.
Up to 27.5 fpm loaded

LOWERING

Up to 21.5 fpm empty
Up to 25.5 fpm loaded

TIRES / WHEELS

DRIVE

9" x 3" polyurethane

STABILITY

4" x 2" polyurethane

DUAL LOAD

(2) 4" x 2.9" polyurethane

HYDRAULICS

Lift cylinder is hard chrome and provides smooth lifting and lowering. Pump unit includes premium 3kw solenoid fired DC motor and reservoir.

DRIVE

24-Volt 1.3kw AC drive motor delivers high torque and efficiency to extend duty cycle.

ELECTRICAL

24-Volt ZAPI AC travel control provides high performance throughout the entire speed range. Travel speed remains constant relative to throttle position regardless of load. Separately fused power control circuits, quick disconnect EPD power cut off, and control head mounted hour meter / battery discharge indicator combination gauge complete the system.

BRAKES

Electronic neutral braking assists in delivering smooth and accurate control during operation, while the unit's electro-mechanical brake provides secure stopping power when activated.



S30

Powered Drive Straddle Truck

Compact design for general material handling, stacking and work positioning in tight areas or those where rider equipment may pose a danger to personnel.

OPERATOR CONTROLS

Offset steer arm provides excellent line of sight for operators and allows them to easily walk astride the vehicle during travel. The offset design also allows the vehicle to comfortably right angle stack standard pallets in aisles under seven feet.

Travel, lift, and lower functions are located in the ergonomic operator handle. All operator controls are accessible without having to lift the hand from the handle.

Angle grips are designed to allow easy operation with either hand. Wrap around guard, reversing switch, thumb control, and horn are standard. Low mounted steer arm offers excellent operator comfort and minimum steering effort.

CHASSIS AND MAST

Heavy duty welded steel chassis and I-beam channel mast for added durability and service life. Class II ITA 16.25" x 32" adjustable carriage comes standard with 42" x 4" x 1.5" forks and 36" load basket rest.

Telescoping mast includes a plexiglass mast guard and provides a 128" maximum fork elevation with a single cylinder. When collapsed the mast is a height of 83.8".

4" wide adjustable straddle legs allows for configurations to fit various sized pallets. Straddle leg inside dimension (ID) can be set at 38" to 50" in 4" increments.

Unit features tandem load wheels with fully enclosed wheel guards and flush mounted axles prevent wheel and axle damage.

SERVICEABILITY

Removable two piece power head cover allows for easy maintenance and access to all vehicle components.

EQUIPMENT OPTIONS

- Hand held remote lift & lower control box with 3' coiled cord



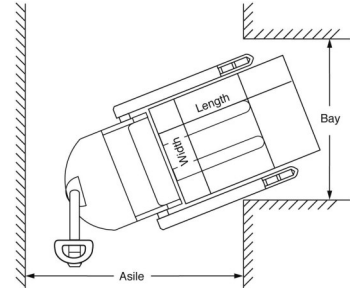
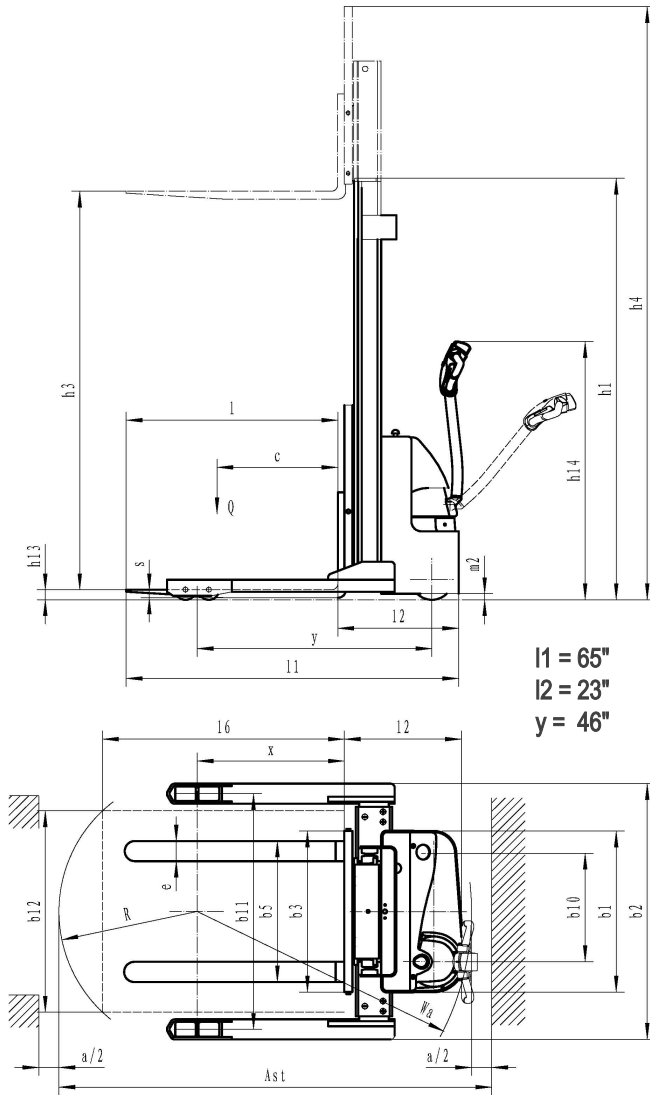

Aisle Guide

S30-128- Right Angle Stacking

Load Width	Load Length		
	36"	40"	48"
36"	61"	61"	61"
40"	62"	63"	63"
48"	67"	67"	67"

For ease of use add 8" to aisle dimension listed

Aisle dimensions listed above assume the minimum bay width to be straddle OD plus 5" (2.5" on each either side of straddle leg). Straddle OD is the load width plus 10".

Truck performance may vary due to application requirements and changes in model design.

All measurements shown are in standard "inch" units

Model #	Mast	Lift Height	Col Height	Free Lift	Ext Height w/LBR	Adjustable Straddle Leg 4" Increments		Weight Complete
		h3	h1			ID	OD	
S30-128	Two Stage	128	83.8	0	164	38 to 50	46 to 58	2000 lbs

3000 Lbs. Capacity @ 24" Load Center ITA Class II Fork Carriage

S30-128	Two Stage	128	83.8	0	164	38 to 50	46 to 58	2000 lbs
---------	-----------	-----	------	---	-----	----------	----------	----------

³ Complete weight includes truck, battery and charger